

COMPUTER  
I *"KLASSISK"*  
MUSIK-UNDERVISNING

v. Arne Dich

# Du har det hele - mellem ørerne

- ▣ Du kunne tale - før du lærte grammatik
  - - du havde allerede grammatikken i ørerne
- ▣ Du har hørt og spillet musik i mange år
  - - og kender allerede musikkens teori
- ▣ Med de rigtige redskaber
  - - kan du selvfølgelig arrangere

# Sibelius – nodeprogram

4-stemmig sats fra Højskolesangbogen



Nydelig S-A-T-B Sats

Skal spilles af musikskolens blandede orkester

# Photoscore 1

## Genkendelse af nodelinjer

### 2. Liebesklage

Andante

Béla Bartók 1881-1945

The image displays a musical score for the piece "2. Liebesklage" by Béla Bartók. The score is arranged in five systems. The first system includes a guitar staff (5-line staff, treble clef, 8va, Solo), a piano staff (5-line staff, treble clef, 8va, p dolce), a vocal staff (5-line staff, treble clef, 2/4, Solo, p dolce), and a bass TAB staff (4-line bass TAB staff, bass clef, 8va, Solo, p dolce). The second system shows the guitar and piano parts. The third system shows the vocal part with the lyrics "Fejlen har jeg lavet med vilje" in red text. The fourth system shows the bass TAB staff with the text "May Require Manual Adjustment" in red. The fifth system shows the guitar and piano parts with the instruction "Tutti" in red. The score is set against a blue background.

# Photoscore 2 , rettelse af læsefejl

put - Liebesklage - at 100% +]

Window Help

Page 1 of 1

100% 200%

Send to Sibelius

Transpose Rescore

## 2. Liebesklage

Béla Bartók 1881-1945

Andante Solo

*p dolce*

Staff 1

Vælg Instrumenter

Bela Bartok 1881-1945

Andante solo

*p dolce*

solo

*p dolce*

solo

*p dolce*

8

tutti

Ritmisk fejlliste

- Page 1, Bar 1, Staff 2
- Page 1, Bar 1, Staff 3
- Page 1, Bar 2, Staff 1

Noder redigeres som i Sibelius

# Nu i Sibelius

Vi glemte vist at rette fejlene  
Instrumenterne valgte jeg

The image displays a musical score for the piece "Nu i Sibelius". The score is divided into two systems. The first system includes parts for Flute (B<sup>5</sup>), English Horn (A), Clarinet in A, and Bass Clarinet in B<sup>b</sup>. The second system includes parts for Flute (Fl.), English Horn (Eng. Hn), Clarinet (Cl.), and Bass Clarinet (B. Cl.).

**System 1:**

- Flute (B<sup>5</sup>):** Starts with a *solo* marking. The melody is in 2/4 time.
- English Horn (A):** Starts with a *dolce* marking.
- Clarinet in A:** Starts with a *solo* marking.
- Bass Clarinet in B<sup>b</sup>:** Starts with a *p dolce* marking, followed by a *solo* marking.

**System 2:**

- Fl.:** Starts with a measure rest (8), then a *dolce p* marking, followed by a *tutti* marking.
- Eng. Hn:** Starts with a *tutti* marking.
- Cl.:** Starts with a *tutti* marking.
- B. Cl.:** Starts with a *tutti* marking.

The score is written in 2/4 time and features various dynamics and articulations such as *solo*, *dolce*, *p*, and *tutti*. The key signature is one sharp (F#).

# Sammenspil

- ▣ De 20 min. med læreren er ikke nok !
- ▣ Sammenspil og socialt samvær !
- ▣ Materialer må du ofte selv lave !
- ▣ [www.DichMusik.dk](http://www.DichMusik.dk) [LINK](http://www.dichmusik.dk) : [www.dichmusik.dk](http://www.dichmusik.dk)
  - ▣ Arr.-kursus og sammenspilsmaterialer

# Arrangementer af studerende

- ▣ AM-ere [LINK](#)
- ▣ [www.dichmusik.dk/arrangement/END.html](http://www.dichmusik.dk/arrangement/END.html)
  
- ▣ Klassiske studerende efter 10 lektioner [LINK](#)
  - [www.dichmusik.dk/ITogSATS.html](http://www.dichmusik.dk/ITogSATS.html)



# Midi-filer

- ▣ Din bratsch-elev skal spille Mozarts 1. kvartet
- ▣ [www.ClassicalArchives.com](http://www.ClassicalArchives.com) LINK
- ▣ Import midi-fil
  - ▣ Har 32-dele og trioler *(lyde til solo)*

# SmartMusic

- ▣ Akkompagnement på computeren
- ▣ Bruges meget af f.eks. Kristian Steenstrup
- ▣ Både klassisk og rytmisk

Educator Subscription

\$140/year

Student Subscription

\$36/year

- ▣ [www.smartmusic.com](http://www.smartmusic.com)

# SmartMusic is Interactive Music Software

Practice with background accompaniment. Get better faster.



Launch SmartMusic. Plug in the microphone, and start practicing. SmartMusic is ideal for woodwind, brass, percussion, string, and vocal musicians of all levels. Students play or sing their part with background accompaniment and get instant feedback on their computer.

Built-in tools  
allow students to:

*Slow the tempo or  
repeat a difficult section  
to master technical  
challenges.*

*Click on a note  
to see a chart showing  
the correct fingering.*

*Access  
the tuner.*

*See that green  
notes are correct.  
Red notes are early, late,  
or have the wrong pitch.*

**Tempo**

130

Click

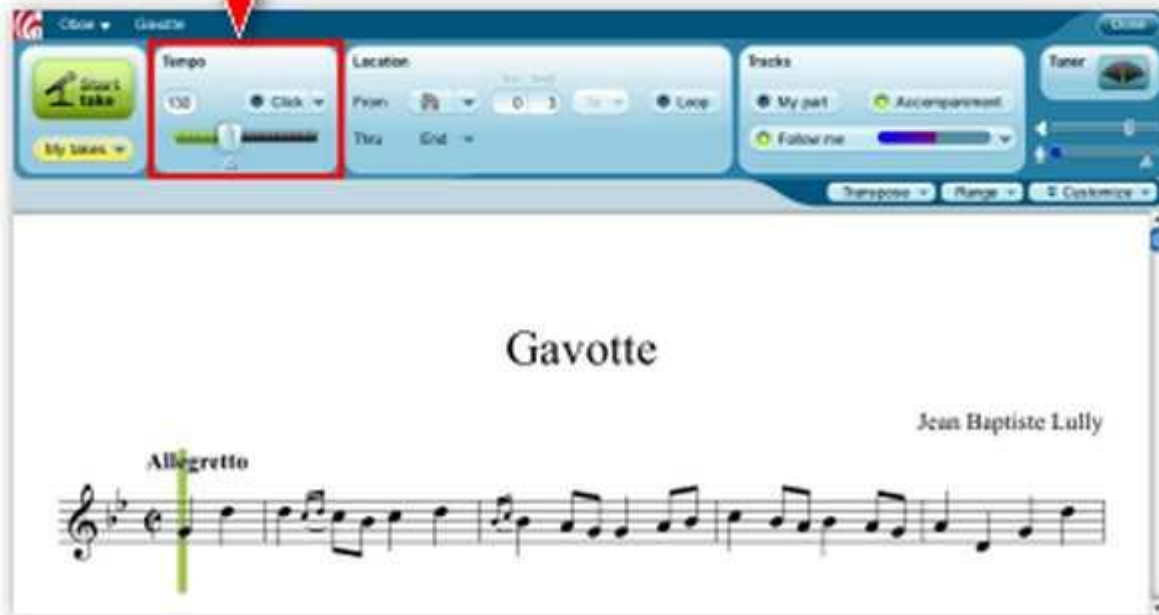

Close Gavotte

Tempo

130 Click

Location

From 0 3 To Loop

Tracks

My part Accompaniment

Follow me

Tuner

Transpose Range Customize

### Gavotte

Jean Baptiste Lully

Allegretto



## Exercises motivate and challenge students



The screenshot displays the SmartMusic software interface. At the top, the title bar reads "Bb Clarinet Scales - Harmonic Minor, Sixteenth Notes - Arpeggio Up Scale Down (254)". The interface includes several control panels: "Tempo" with a "Start take" button and a "Click" dropdown; "Location" with "From" and "To" fields and a "Loop" button; "Tracks" with "My part" and "Accompaniment" options; and a "Tuner" section. Below these panels, the musical score is displayed on four staves. The first staff has a green vertical bar indicating the start of the exercise. The music is in B-flat major (two sharps) and 2/4 time, featuring a sequence of sixteenth notes and eighth notes.

Scales and arpeggios are rarely a student's favorite practice material, but SmartMusic makes learning these fundamental skills challenging and fun. More than 50,000 scale, interval, arpeggio, twister, and rhythm exercises are included in SmartMusic. Each can be customized to any key and articulation, has multiple accompaniment styles to choose from, and is displayed on-screen with assessment and grading.

# Transpose

Transpose to any key

Before:

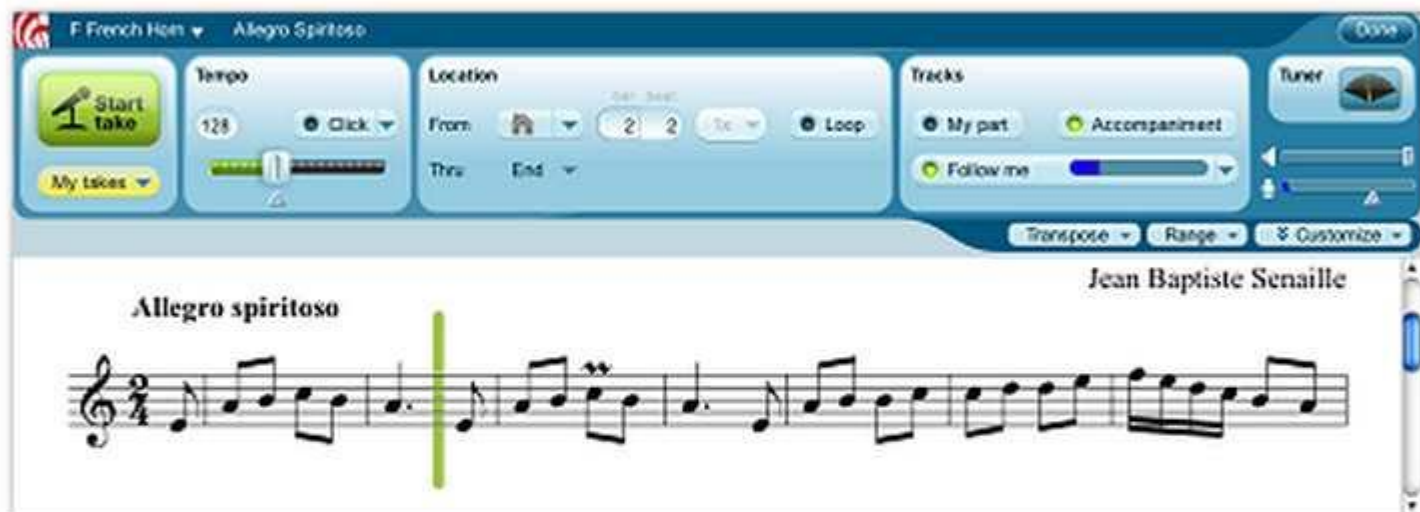

The screenshot shows a music software interface with a blue header. The title bar reads "F French Horn" and "Allegro Spiritoso". On the left, there are buttons for "Start take" and "My takes". The "Tempo" section shows "128" and a "Click" button. The "Location" section shows "From" and "Thru" fields with "2 | 2" and "End" respectively, and a "Loop" button. The "Tracks" section shows "My part" and "Accompagnement" with a "Follow me" slider. A "Tuner" icon is on the right. Below the controls, the score is titled "Allegro spiritoso" and "Jean Baptiste Senaille". The music is in 2/4 time, starting with a treble clef and a key signature of one sharp (F#). A vertical green line is positioned at the beginning of the second measure.

After:



The screenshot shows the same music software interface as above, but the score has been transposed. The title bar now reads "F# French Horn" and "Allegro Spiritoso". The "Tracks" section shows "My part" and "Accompagnement" with a "Follow me" slider. The score is titled "Allegro spiritoso" and "Jean Baptiste Senaille". The music is in 2/4 time, starting with a treble clef and a key signature of two sharps (F# and C#). A vertical green line is positioned at the beginning of the second measure.

# Practice Loops

Practice loops help students concentrate on difficult passages



A screenshot of the music software interface. A red arrow points from the close-up above to the 'Location' section of the software's control bar, which is also highlighted with a red border. The control bar includes 'Tempo' (set to 100), 'Location' (with 'From' and 'Thru' fields), 'Tasks' (with 'My part' and 'Accompaniment' buttons), and a 'Tuner' button. Below the control bar, the musical score for Violin I is displayed, showing measures 18 through 25. The score includes various musical notations such as slurs, accents, and dynamics. At the bottom of the page, there is a copyright notice: '© 2007 BELMUN HILLS PUBLISHING CORP. (ASCAP), a division of ALFRED PUBLISHING CO., INC. All Rights Reserved including Public Performance'.



# Fingering Charts

Beginning students can learn fingerings instantly

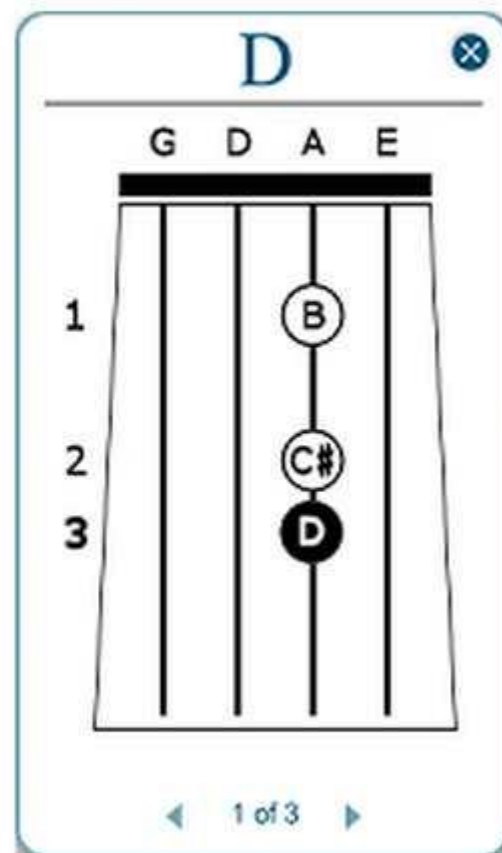
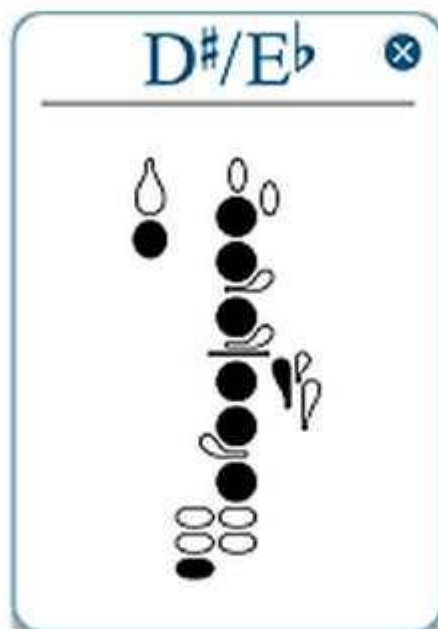
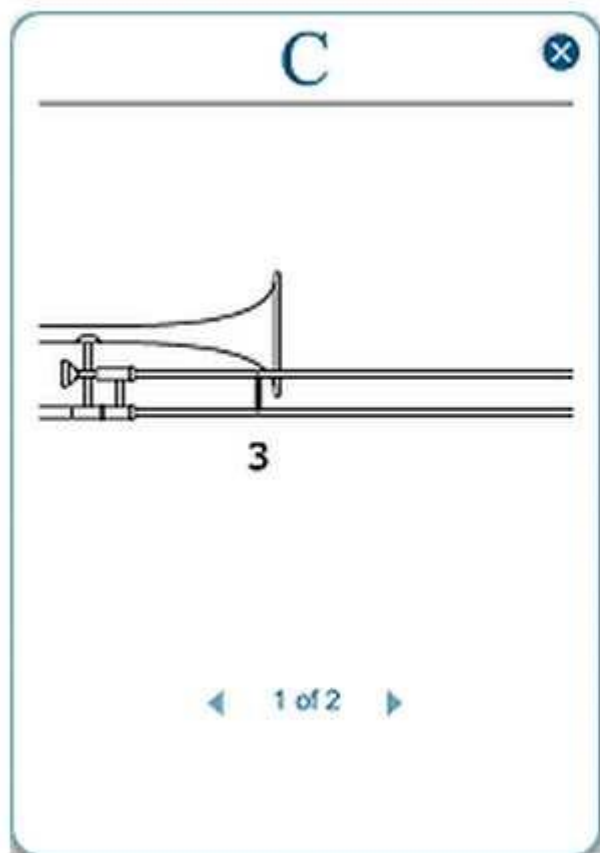

If a student is unsure of the fingering for any note, they need only to click on it. A fingering chart – specific to that note and the student's instrument – appears on the screen.

- ▣ 50.000 Øvelser - med akkompagnement
- ▣ Det klassiske standard Repertoire
- ▣ F.eks. Hændelsonater for alle instrumenter
- ▣ Aebersold, Marsalis og anden rytmisk musik



**Det var så det !**

**Spørgsmål ?**